



Most Widely Accepted and Trusted

ICC-ES Evaluation Report

ESR-3415

ICC-ES | (800) 423-6587 | (562) 699-0543 | www.icc-es.org

Reissued 09/2017
This report is subject to renewal 09/2019.

DIVISION: 06 00 00—WOOD, PLASTICS AND COMPOSITES

SECTION: 06 50 00—STRUCTURAL PLASTICS

SECTION: 06 63 00—PLASTIC RAILINGS

REPORT HOLDER:

SHORELINE VINYL SYSTEMS, INC.

**1114 PARK LANE
DENTON, MARYLAND 21629**

EVALUATION SUBJECT:

100 SERIES, 200 SERIES, 300 SERIES AND R-RAIL GUARDRAIL SYSTEMS



Look for the trusted marks of Conformity!

“2014 Recipient of Prestigious Western States Seismic Policy Council (WSSPC) Award in Excellence”



A Subsidiary of  INTERNATIONAL CODE COUNCIL™

ICC-ES Evaluation Reports are not to be construed as representing aesthetics or any other attributes not specifically addressed, nor are they to be construed as an endorsement of the subject of the report or a recommendation for its use. There is no warranty by ICC Evaluation Service, LLC, express or implied, as to any finding or other matter in this report, or as to any product covered by the report.



ICC-ES Evaluation Report

ESR-3415

Reissued September 2017

This report is subject to renewal September 2019.

www.icc-es.org | (800) 423-6587 | (562) 699-0543

A Subsidiary of the International Code Council®

DIVISION: 06 00 00—WOOD, PLASTICS AND COMPOSITES

Section: 06 50 00—Structural Plastics

Section: 06 63 00—Plastic Railings

REPORT HOLDER:

SHORELINE VINYL SYSTEMS, INC.

1114 PARK LANE

DENTON, MARYLAND 21629

(410) 364-9050

www.shorelinevinyl.com

EVALUATION SUBJECT:

100 SERIES, 200 SERIES, 300 SERIES AND R-RAIL GUARDRAIL SYSTEMS

ADDITIONAL LISTEES:

WOLF HOME PRODUCTS

20 WEST MARKET STREET

YORK, PENNSYLVANIA 17401

www.wolfhomeproducts.com

**PRODUCT NAME: TRADITIONAL (100 SERIES)
DESIGNER (200 SERIES)**

TW PERRY RAIL

8101 SNOUFFER SCHOOL ROAD

GAITHERSBURG, MARYLAND 20879

www.twperry.com

**PRODUCT NAME: TRADITIONAL (100 SERIES)
DESIGNER (200 SERIES)**

1.0 EVALUATION SCOPE

1.1 Compliance with the following codes:

- 2015, 2012, 2009 and 2006 *International Building Code*® (IBC)
- 2015, 2012, 2009 and 2006 *International Residential Code*® (IRC)

Properties evaluated:

- Structural
- Durability
- Surface-burning characteristics

1.2 Evaluation to the following green code(s) and/or standards:

- 2016 California Green Building Standards Code

(CALGreen), Title 24, Part 11

- 2015, 2012 and 2008 ICC 700 *National Green Building Standard*™ (ICC 700-2012 and ICC 700-2008)

Attributes verified:

- See Section 3.1

2.0 USES

The bracketed-tee top rail systems (100 Series and 300 Series), rectangular top rail system (200 Series) and bracketed-bread loaf top rail system (R-Rail) described in this report are limited to exterior use as guards for balconies, porches, and decks of structures of Type V-B construction (IBC) and other types of construction in applications where untreated wood is permitted by IBC Section 1406.3, or in structures constructed in accordance with the IRC.

3.0 DESCRIPTION

3.1 General:

The 100 Series, 200 Series and 300 Series and R-Rail systems are polyvinyl chloride (PVC) products manufactured by an extrusion process in three colors: white, almond and khaki. The products are fabricated, packaged and sold by the report holder doing business as Shoreline Rail. The 100 Series and 200 Series products are also sold by TW Perry Rail and Wolf Home Products under the product series names Traditional and Designer, respectively.

The attributes of the PVC guardrail products have been verified as conforming to the provisions of (i) CALGreen Section A5.406.1.2 for reduced maintenance; (ii) ICC 700-2015 and ICC 700-2012 Sections 601.7, 11.601.7, and 12.1(A).601.7 for site-applied finishing materials; and (iii) ICC 700-2008 Section 601.7 for site-applied finishing materials. Note that decisions on compliance for those areas rest with the user of this report. The user is advised of the project-specific provisions that may be contingent upon meeting specific conditions, and the verification of those conditions is outside the scope of this report. These codes or standards often provide supplemental information as guidance. See Section 5.7 for limitations on termite-resistance use.

3.2 Guardrail Systems:

3.2.1 General: The 100 Series, 200 Series and R-Rail systems are designed for installed heights of 36 and 42 inches (914 mm and 1067 mm) when used in IRC applications, and 42 inches (1067 mm) when used in IBC applications with a maximum length of 96 inches

(2438 mm) when measured from the edge-of-structure to edge-of-structure. The 100 Series, 200 Series, 300 Series and R-Rail systems are comprised of several different types of interchangeable components. These include a rectangular rail, T-Rail, R-Rail and Nexus® T-Rail as top rail components, three different sizes of plastic balusters, an aluminum baluster, a bottom rail, and various mounting brackets and architectural components as described in the manufacturer's quality control manual.

The 300 Series system is designed for an installed height of 42 inches (1067 mm) when used in IBC applications and is designed for installed heights of 36 inches (914 mm) or 42 inches (1067 mm) when used in IRC applications. The 300 Series, when constructed under the IBC for other than one- and two-family dwellings, has a maximum length of 96 inches (2438 mm) when measured from the edge-of-structure to edge-of-structure, and 120 inches (3048 mm) when used in IRC applications and one- and two-family dwellings constructed under the IBC. See Figure 1 for typical component cross sections.

3.2.1.1 Rectangular Rail: The rectangular rail is manufactured with dimensions of 2 by 3¹/₂ inches (51 by 89 mm) and a wall thickness of 0.095 inch (2.4 mm). The rail, when used as a top rail in the 200 Series, is designed to be installed with a P-channel insert fabricated from 6063-T6 aluminum alloy. The rectangular rail is also used as the bottom rail in the 100 Series, 200 Series, 300 Series and R-Rail systems.

3.2.1.2 T-Rail: The T-Rail is a tee-shaped component with a width of 3¹/₂ inches (89 mm), a depth of 3¹/₂ inches (89 mm) and a wall thickness of 0.090 inch (2.3 mm), and is used as the top rail in the 100 Series. The T-Rail is designed to be installed with a P-channel insert fabricated from 6063-T6 aluminum alloy.

3.2.1.3 R-Rail: The R-Rail is a bread loaf-shaped component with a width of 3 inches (76 mm), a depth of 3¹/₂ inches (89 mm) and a wall thickness of 0.125 inch (3.2 mm). The R-Rail is designed to be installed with a 2.7-by-0.80-inch (69 by 20.3 mm) 6063-T6 aluminum alloy insert.

3.2.1.4 Nexus® T-Rail: The Nexus® T-Rail is a tee-shaped component with a width of 3 inches (76 mm), a depth of 1³/₄ inches (44 mm) and a wall thickness of 0.065 inch (1.7 mm), and is used as the top rail in the 300 Series. The Nexus® T-Rail is designed to be installed with a 1.55-by-2.78-inch (39 by 71 mm), U-profile, 6063-T6 aluminum insert in guard widths up to 8 feet and a T-profile aluminum insert in guard widths up to 10 feet.

3.2.1.5 Baluster: The plastic balusters are fabricated in three sizes: 1¹/₄ by 1¹/₄ inches (32 by 32 mm) with a wall thickness of 0.07 inch (1.8 mm); 1³/₈ by 1³/₈ inches (35 by 35 mm) with a wall thickness of 0.07 inch (1.8 mm); and 1¹/₂ by 1¹/₂ inches (38 by 38 mm) with a wall thickness of 0.07 inch (1.8 mm). The round aluminum baluster is fabricated from 6063-T5 or 6063-T6 aluminum alloy with a ³/₄-inch diameter (19mm) and a wall thickness of 0.05 inch (1.3 mm).

3.2.2 Durability: When subjected to weathering, insect attack, and other decaying elements, material used to manufacture the 100 Series, 200 Series, 300 Series and R-Rail systems are equivalent in durability to preservative-treated or naturally durable lumber when used in locations described in Section 2.0.

3.2.3 Surface-burning Characteristics: When tested in accordance with ASTM E84, 100 Series, 200 Series, 300 Series and R-Rail systems have a flame-spread index of no greater than 200.

4.0 DESIGN AND INSTALLATION

4.1 General:

Installation of the 100 Series, 200 Series, 300 Series and R-Rail systems must comply with this report and the report holder's published installation instructions. The report holder's published installation instructions must be available at the jobsite at all times during installation.

4.2 Guardrail:

4.2.1 General: The 100 Series, 200 Series, 300 Series and R-Rail systems are assembled using a bracketed component assembly. The balusters are installed by insertion into a routed opening. The routed openings are fabricated so that a maximum opening of 3.9 inches (99 mm) between balusters is maintained. One 1¹/₂-by-1¹/₂-inch-square footblock is installed at the midpoint of the bottom rail for guardrail assemblies spanning more than 48 inches (1220 mm). The bottom rail of the 100 Series, 200 Series and R-Rail systems may be installed without any additional reinforcement. The standard 2-by-3¹/₂-inch (51 mm by 89 mm) rectangular bottom rail of the 300 Series system may be installed without any additional reinforcement. The alternative 2¹/₄-by-1³/₄-inch (57 mm by 44 mm) rectangular bottom rail of the 300 Series system includes additional reinforcement.

4.2.2 Bracketed Component Assembly: The brackets used to attach the top and bottom rails to structures and the top rail to the bracket must be attached as shown in Table 2. The 100 Series, 200 Series, 300 Series standard bottom rail, and R-Rail systems use a plastic bracket. The 300 Series system top rail and alternative bottom rail uses an aluminum bracket. The top rail components must be reinforced as described in Sections 3.2.1.1, 3.2.1.2, 3.2.1.3 and 3.2.1.4, respectively.

4.2.3 Structural: The 100 Series, 200 Series, 300 Series and R-Rail systems will resist the loads specified in the applicable code when installed at a maximum length as prescribed in Table 1.

5.0 CONDITIONS OF USE

The 100 Series, 200 Series, 300 Series and R-Rail systems described in this report comply with, or are suitable alternatives to what is specified in, those codes listed in Section 1.0 of this report, subject to the following conditions:

5.1 The 100 Series, 200 Series, 300 Series and R-Rail systems described in this report are limited to exterior use as guards for balconies, porches, and decks of structures of Type V-B construction (IBC) and other types of construction in applications where untreated wood is permitted by IBC Section 1406.3; or in structures constructed in accordance with the IRC.

5.2 Installation must comply with this report, the report holder's published installation instructions and the applicable code. Only those fasteners and fastener configurations described in this report have been evaluated for the installation of the 100 Series, 200 Series, 300 Series and R-Rail systems. When the report holder's published installation instructions differ from this report, this report governs.

5.3 The use of wood posts, with or without post sleeves, is outside the scope of this report.

5.4 The compatibility of the fasteners and other metal hardware with the supporting construction, including chemically treated wood, is outside the scope of this report.

- 5.5 Adjustment factors outlined in the AF&PA *National Design Specification* and applicable codes do not apply to the allowable capacity and maximum spans for the 100 Series, 200 Series, 300 Series and R-Rail systems.
- 5.6 The 100 Series, 200 Series, 300 Series and R-Rail systems must be fastened directly to supporting construction. Where required by the code official, engineering calculations and construction documents consistent with this report must be submitted for approval. The calculations must verify that the supporting construction complies with the applicable building code requirements and is adequate to resist the loads imparted upon it from the products and systems discussed in this report. The documents must contain details of the attachment to the supporting structure consistent with the requirements of this report. The documents must be prepared by a registered design professional where required by the statutes of the jurisdiction in which the project is to be constructed.

5.7 The 100 Series, 200 Series, 300 Series and R-Rail systems are fabricated and packaged in Denton, Maryland, by Shoreline Vinyl Systems, Inc. (doing business as Shoreline Rail), under a quality control program with inspections by ICC-ES.

6.0 EVIDENCE SUBMITTED

Data establishing compliance of the guard system with the ICC-ES Acceptance Criteria for Deck Board Span Ratings and Guardrail Systems (Guards and Handrails) (AC174), dated January 2012 (editorially revised December 2014).

7.0 IDENTIFICATION

The 100 Series, 200 Series, 300 Series and R-Rail systems described in this report are identified on each package by a stamp bearing the report holder’s name (Shoreline Rail) or the additional listees’ names (TW Perry Rail and Wolf Home Products); the product name; the allowable span, the date of manufacture; and the evaluation report number (ESR-3415).

TABLE 1—MAXIMUM GUARDRAIL SPAN²

PRODUCT NAME	APPLICABLE BUILDING CODE ³		MAXIMUM SPAN (ft-in) ¹
	IBC	IRC	
100 Series	Yes	Yes	8’ – 0”
200 Series	Yes	Yes	8’ – 0”
R-Rail	Yes	Yes	8’ – 0”
300 Series	Yes	Yes	8’ – 0”
300 Series ⁵	See note 4	Yes	10’ – 0”

For SI: 1 inch = 25.4 mm, 1 ft = 305 mm.

¹Maximum span must be measured from edge-of-structure to edge-of-structure.

²Maximum allowable span has been adjusted for durability. No further increases are permitted.

³Indicates compliance with the respective building codes.

⁴Allowed in one- and two-family dwellings only.

⁵10'-0" maximum span allowed when using the reinforced 300 Series bottom rail.

TABLE 2—GUARD FASTENING SCHEDULE

GUARD SYSTEM	CONNECTION	FASTENERS
100 Series	Rail bracket to post	Six No. 10 by 1 ¹ / ₂ -inch, Phillips pan-head, self-drilling, plated steel screws
	Rail bracket to rail	Two No. 10 by 1-inch Phillips pan-head, self-drilling, plated steel screws
R-Rail	Rail bracket to post	Four No. 10 by 2-inch stainless steel wood screws
	Rail bracket to rail	Two No. 10 by 1-inch stainless steel pan head screws
200 Series	Rail bracket to post	Four No. 10 by 1 ¹ / ₂ -inch, Phillips pan-head, self-drilling, plated steel screws
	Rail bracket to rail	Two No. 10 by 1-inch Phillips pan-head, self-drilling, plated steel screws
300 Series	Rail bracket to post	Three No. 8 by 1 ⁵ / ₈ -inch, flat-head, #2 square-drive, Type 17 point, stainless steel screws
	Rail bracket to rail	Two No. 10-16 by 3/4-inch, pan-head, #2 square drive, plated steel, Tek screws

For SI: 1 inch = 25.4 mm.

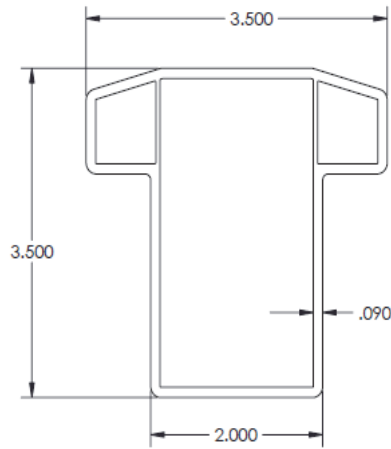

**T-RAIL TOP RAIL
100 SERIES**

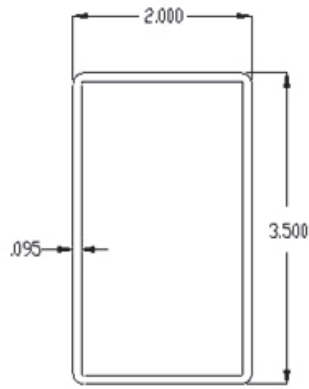

**RECTANGULAR RAIL
200 SERIES TOP RAIL
100, 200, 300 SERIES AND
R-RAIL BOTTOM RAIL**

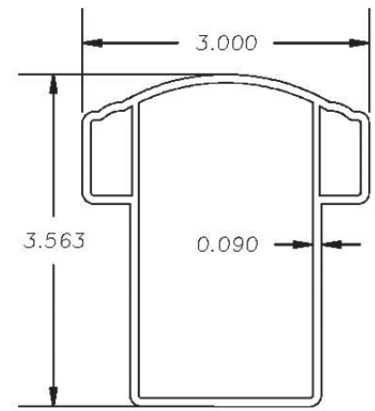

R-RAIL TOP RAIL

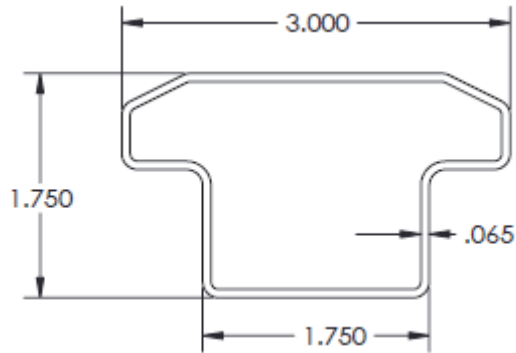

**NEXUS[®] T-RAIL TOP RAIL
(300 SERIES TOP RAIL)**

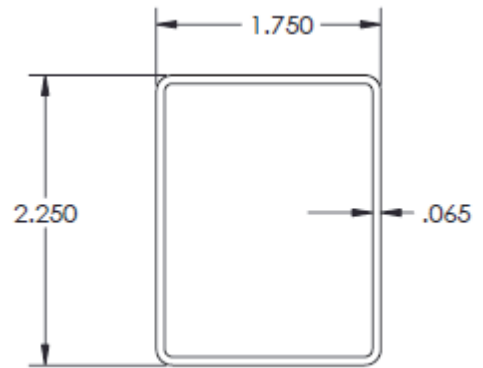

**NEXUS[®] T-RAIL BOTTOM RAIL
(300 SERIES Alternative Bottom Rail)**

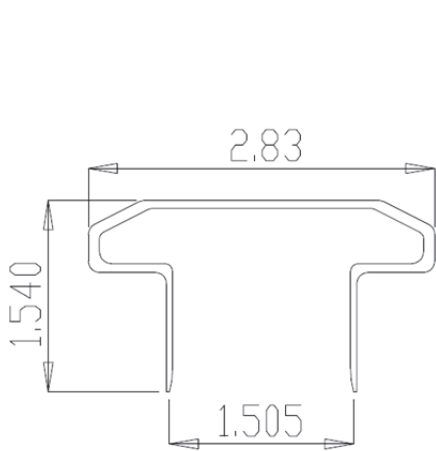

NEXUS[®] CONTOUR INSERT

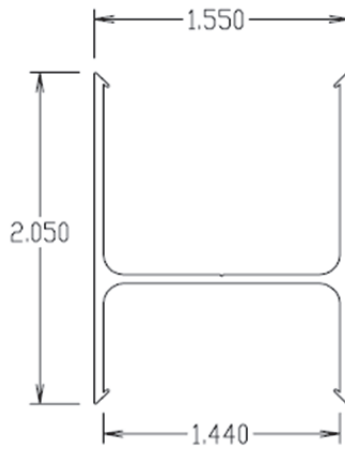

NEXUS[®] BOTTOM RAIL INSERT

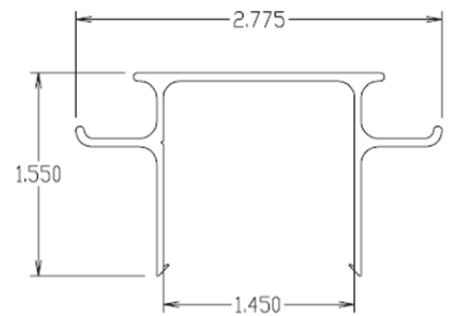

NEXUS[®] MODIFIED U INSERT

FIGURE 1—GUARDRAIL COMPONENT PROFILES

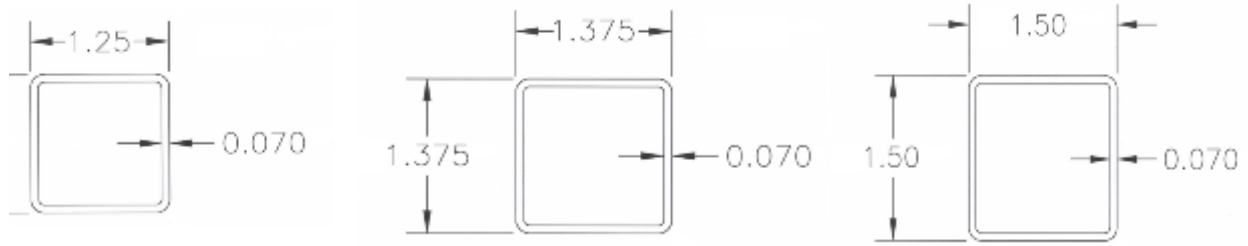

PLASTIC BALUSTERS

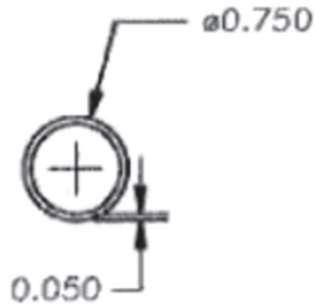

ALUMINUM BALUSTER

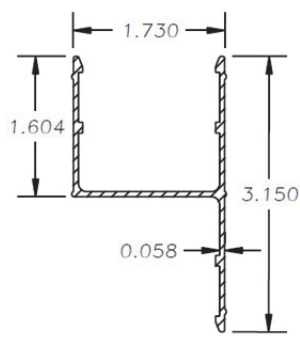

INVERTED "h" ALUMINUM INSERT

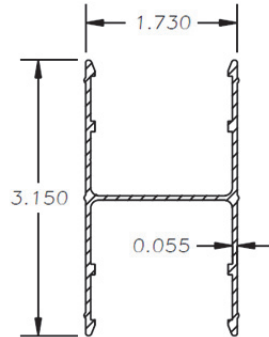

"H" ALUMINUM INSERT

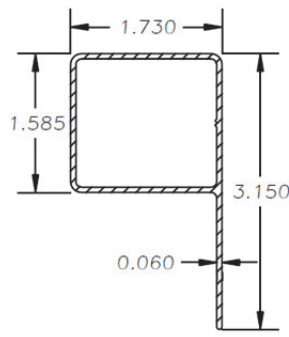

"P" ALUMINUM INSERT

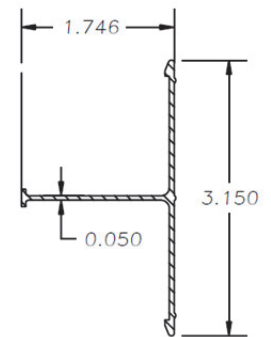

"T" ALUMINUM INSERT

FIGURE 1—GUARDRAIL COMPONENT PROFILES (Continued)

For SI: 1 inch = 25.4 mm.